

Design for Earthquake Safety

G G Schierle, PhD, FAIA

SD-Graphs

based on IBC-03

Equivalent Lateral Force Analysis
for Allowable Stress Design (ASD)
(ASD = LRFD / 1.4)

Light framing with wood panels

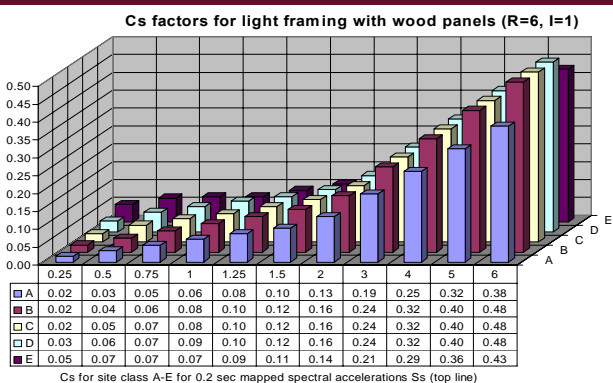

Other low-rise structures

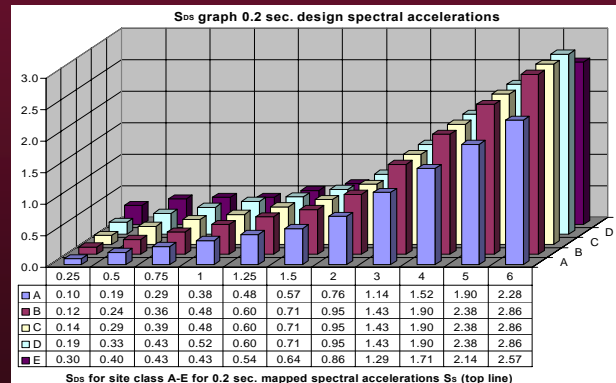

High-rise structures

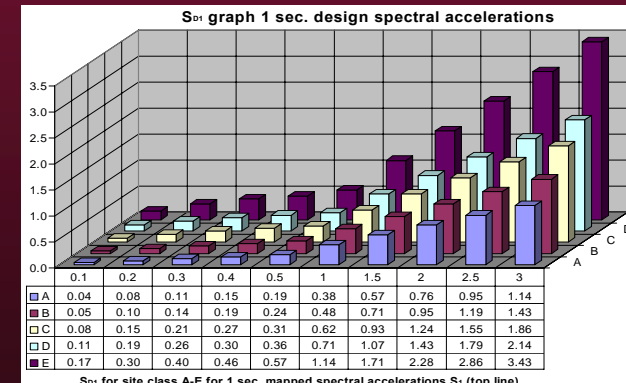

INTERNATIONAL

- Earthquake background
 - Plate Tectonics
 - Largest quakes since 1900
 - Seismic Waves & Epicenter
 - Richter Scale
 - Earthquake cause and effect
- Seismic design background
- Base shear
- Seismic design parameters
- C_s graph for wood panel structures
- S_{DS} graph for low-rise structures
- S_{D1} graph for high-rise structures
- Vertical force and shear distribution
- Example: Two-story wood residence
- Horizontal diaphragms
 - Flexible diaphragm
 - Rigid diaphragm
- Seismic design issues
 - Hill site design
 - Eccentricity
 - Hazard configurations
 - Critical wood-frame items
 - Moment frames
 - Eccentric bracing
 - Visco-elastic bracing
 - Base isolators
- Earthquake fatalities 1970–99
- Light-weight structures

Portions of this document reproduce sections from the 2003 International Building Code, International Code Council, Falls Church, Virginia. Reproduced with permission. All rights reserved. USGS data, courtesy US Geological Survey.

Plate Tectonics

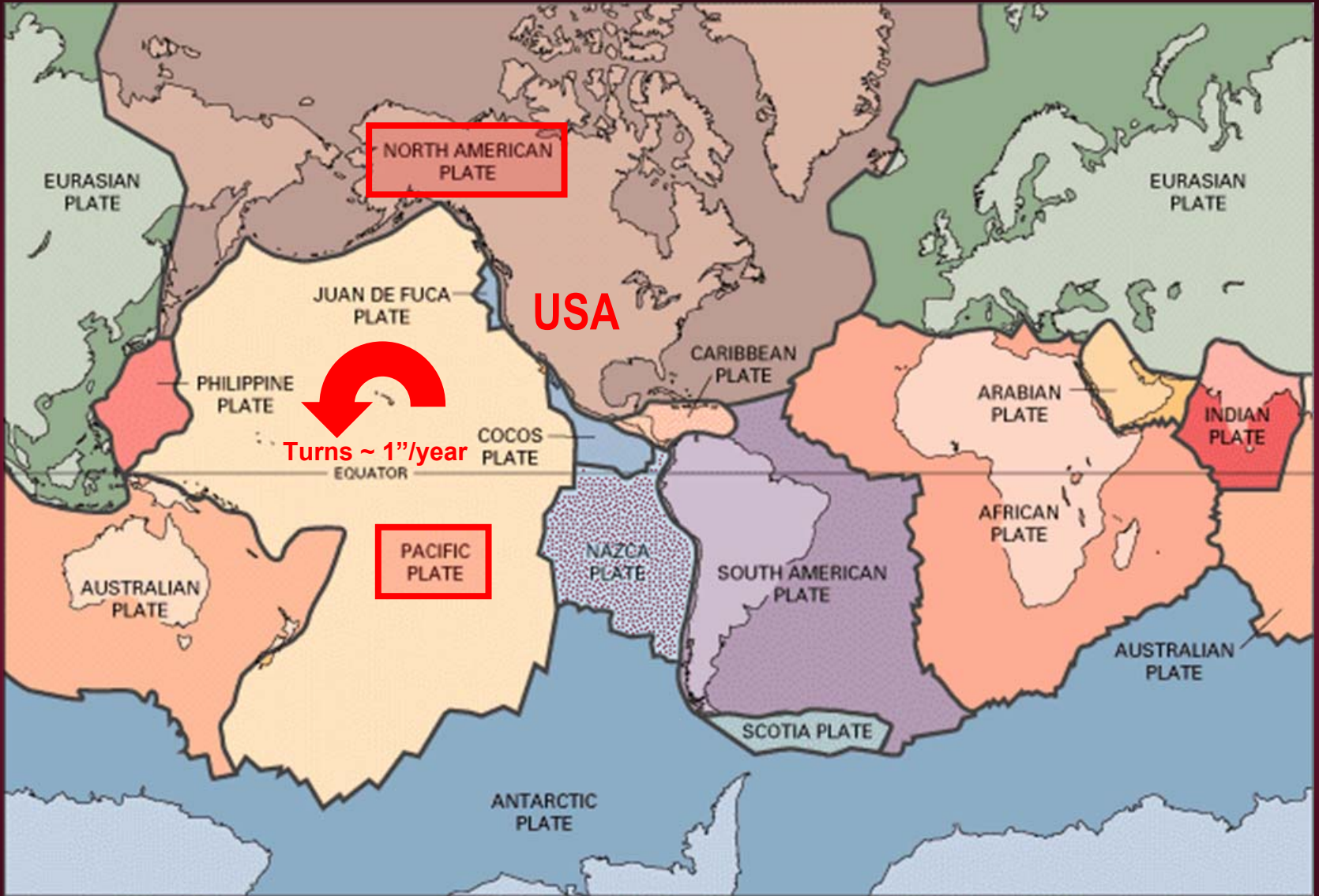

USGS map

World Seismicity: 1975 - 1995

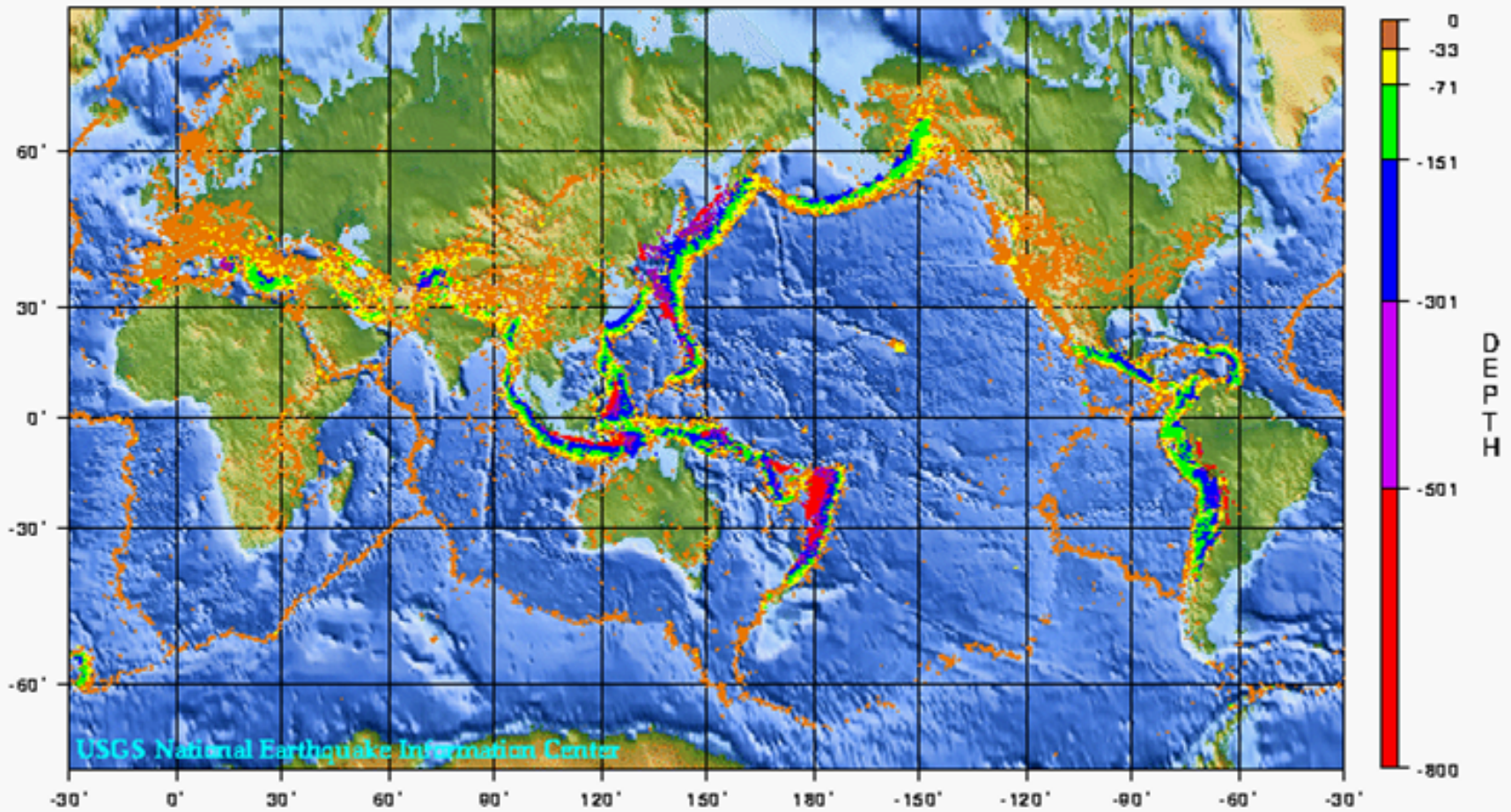

USGS map

Eleven largest earthquakes since 1900

| # | Location | Date | M | # | Location | Date | M |
|---|-------------------|------|-----|----|------------------|------|-----|
| 1 | Chile | 1960 | 9.5 | 6 | Ecuador Coast | 1906 | 8.8 |
| 2 | Alaska | 1964 | 9.2 | 7 | Aleutian Islands | 1965 | 8.7 |
| 3 | Aleutian Islands | 1957 | 9.1 | 8 | India-China | 1950 | 8.6 |
| 4 | Kamchatka | 1952 | 9.0 | 9 | Kamchatka | 1923 | 8.5 |
| 5 | Sumatra (Tsunami) | 2004 | 9.0 | 10 | Indonesia | 1938 | 8.5 |
| | | | | 11 | Kuril Islands | 1963 | 8.5 |

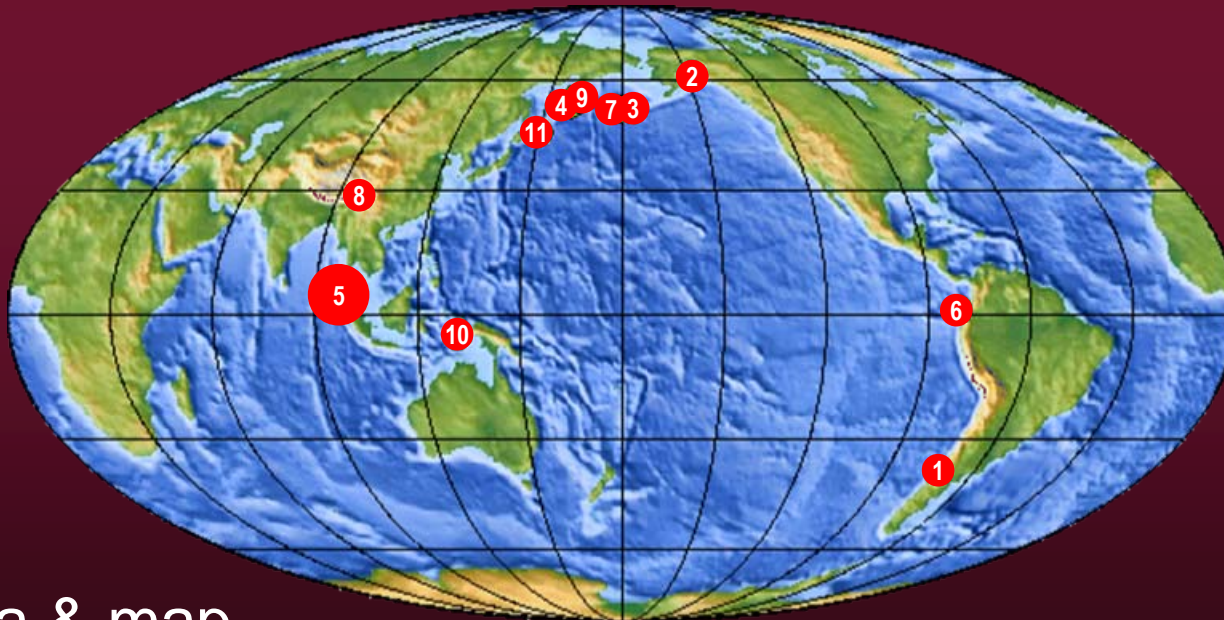

USGS data & map

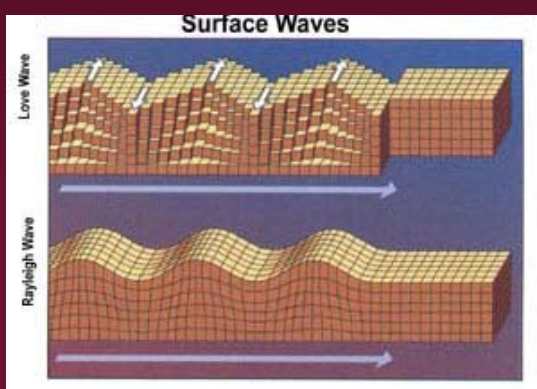
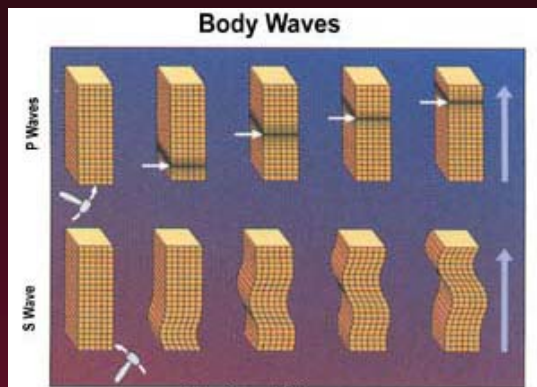

Body waves travel through earth interior

P waves (Primary waves)

travel at very high speed (26,000 mph)

S waves (Secondary waves)

shake perpendicular to wave direction

Surface waves travel near the earth surface

Love waves

shake perpendicular to wave direction

Rayleigh waves

shake in elliptical motion

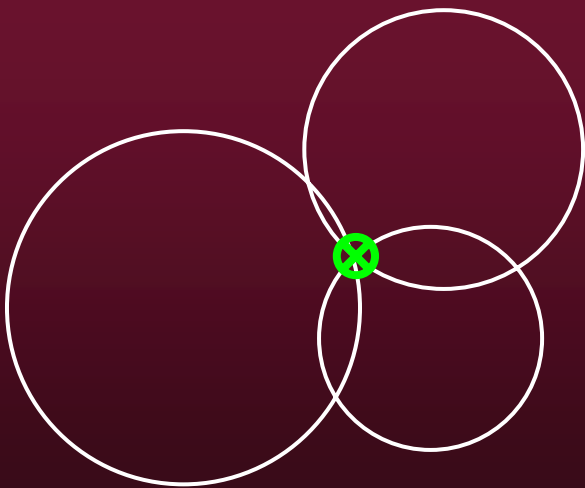

Epicenter Location

The time difference waves of different speed arrive at seismic stations defines the earthquake distance

Distances from 3 stations define the Epicenter

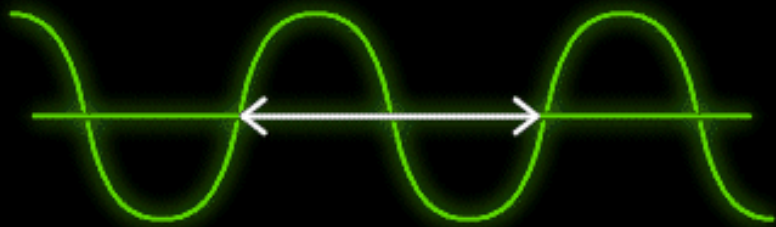

Period

Time of wave cycle. Resonant building & earthquake periods may cause collapse.

Richter scale

Developed 1935 by Charles Richter. Earthquake magnitude as logarithm of wave amplitude recorded by seismograph; adjusted for distance to epicenter.

Each whole number increase represents a tenfold increase in force and amplitude and 31 times more energy.

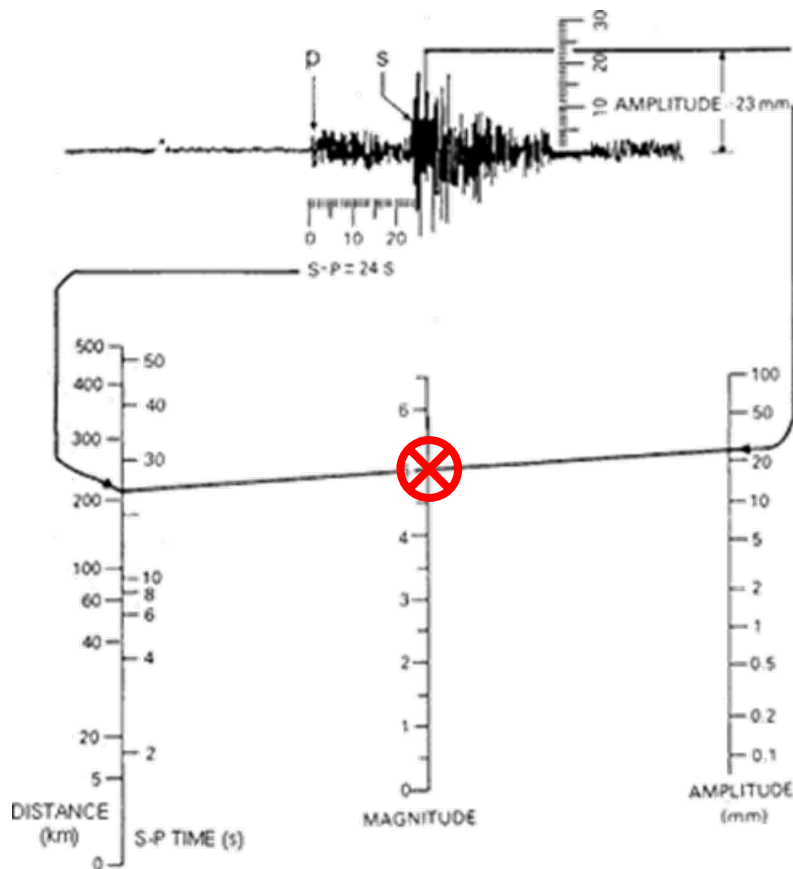

USGS figures

Earthquake cause / effect

Causes:

- Fault slippage (plate movement)
- Volcanic eruptions

- 1 Fault rupture / wave propagation
H = Hypocenter (earthquake focus)
E = Epicenter (above hypocenter)
 - Vertical motion at epicenter
 - Lateral motion at distance

- 2 Lateral slip fault

- 3 Thrust fault

Effect on buildings:

- 4 Overturning

- 5 Base shear

- 6 Bending (first mode)

- 7 Bending (higher mode)

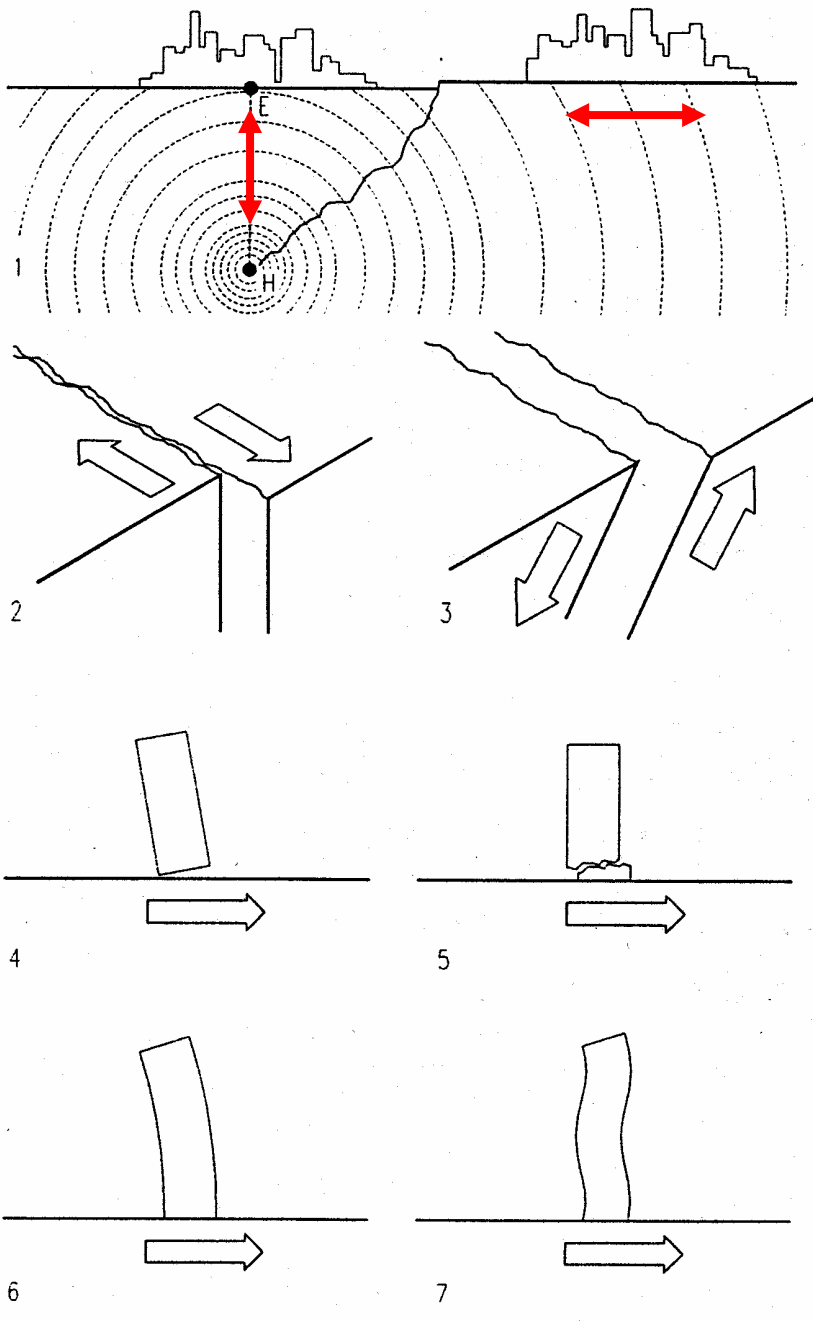

Seismic force = mass x acceleration / R

Mass = building dead weight; R = reduction factor

Acceleration = **Spectral acceleration** = a mass on a rod of equal period as a structure of equal height

Acceleration spectra (Seed, 1976)

define interaction of structures with 4 soil types
(basis of **Equivalent Lateral Force Analysis**)

IBC Design Response Spectrum

$T < T_s$ governs low-rise structures of short periods

$T > T_s$ governs tall structures of long periods

T structure period, $T \sim 1/10$ sec per story

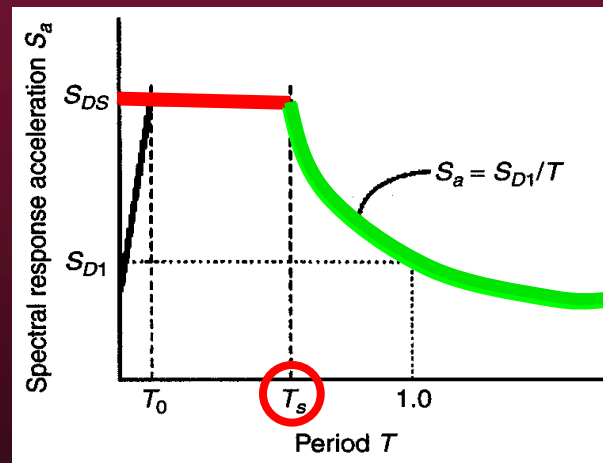
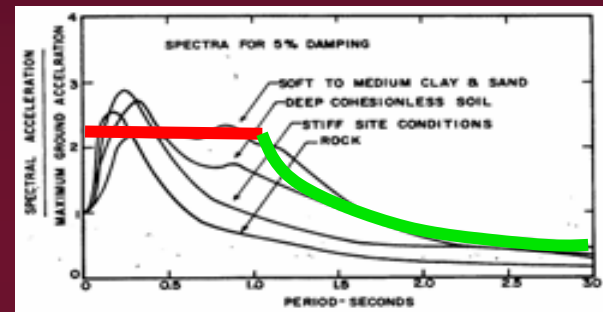
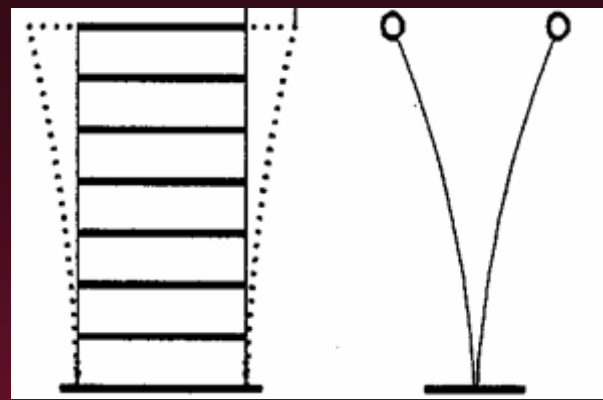

Base shear V

(lateral force at base of building)

$$V = C_S W$$

C_S = seismic coefficient (see graphs)

W = Dead load (+ 25% storage live load)

C_S varies with spectral acceleration S_S & S_1 and type of structure (defined on the following pages)

C_S example in seismic areas:

$C_S \sim 3\%$ for tall steel frame structures

$C_S \sim 15\%$ for low-rise wood structures

$C_S \sim 30\%$ for masonry wall structures

$W = w A$ ($w = \text{DL \{psf\}}$, $A = \text{floor area}$)

w varies with type of construction – for example:

$w \sim 15$ to 25 psf for wood structures

$w \sim 70$ to 100 psf for steel structures

$w \sim 150$ to 200 psf for concrete structures

Optional
 Show Name and Date/Time on Output
 Name
 Include Date and Time in Output

Select Site Location
 Latitude (50.0 to 24.6)
 Longitude (-125.0 to -65.0)
 5-Digit Zip Code
 Calculated Central Values
 Latitude Longitude
 Territories

Select File Location
 Open File Selection Menu

Select Geographic Region
 Conterminous 48 States
 Alaska
 Hawaii
 Puerto Rico
 Culebra

Calculate MCE Spectrum
 Ground Motion
 MCE Ground Motion
 Calculate Ss and S1 Select Soil Factor
 Calculate Spectrum View Spectrum

Output for All Calculations
 MCE Ground Motion - Conterminous 48 States
 Latitude = 33.8800, Longitude = -118.2400
 Period MCE Sa
 (sec) (%g)
 0.2 199.3 MCE Value of Ss, Site Class B
 1.0 078.8 MCE Value of S1, Site Class B

**MCE:
 Maximum
 Considered
 Earthquake**

Clear Selections Clear Output Clear All
 Save To File Print View Maps
 Opening Menu Exit Program

USGS **FEDERAL EMERGENCY MANAGEMENT AGENCY** **BUILDING SEISMIC SAFETY COUNCIL**
science for a changing world

MCE values
 0.2 second S_s
 for low-rise

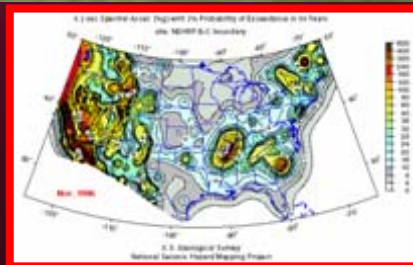

MCE values
 1 second S_1
 for high-rise

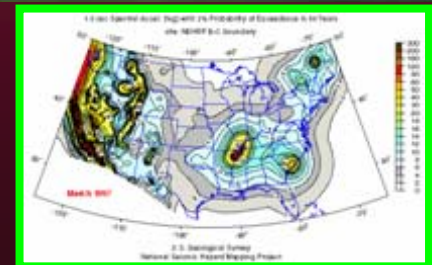

| | |
|--------------------------------------|---------------------------------------|
| Enter Latitude: 37.7795 | Enter Longitude: -122.4195 |
| Enter Latitude: <input type="text"/> | Enter Longitude: <input type="text"/> |
| Enter Latitude: <input type="text"/> | Enter Longitude: <input type="text"/> |

Enter latitude in the left box in *decimal* degrees (range: 24.6 to 50.0)

Enter **negative** longitude in the right box (range: -125.0 to -65.0)

Find latitude and longitude at: <http://www.maporama.com/share/>

OUTPUT (in SA = Spectral Acceleration)

LOCATION 37.7795 Lat. -122.4195 Long.

Interpolated Probabilistic Ground Motion values, in %g, at the site are:

10%PE in 50 yr. 2%PE in 50 yr.

0.2 sec SA 115.35 **182.76** → $S_s = 1.83$ (for low-rise)

1.0 sec SA 53.08 **92.41** → $S_1 = 0.92$ (for high-rise)

Cs factors for light framing with wood panels (R=6, I=1)

R = R-factor (1.5-8) (IBC table 1617.6.2)
 I = Importance factor (IBC table 1604.5)
 I = 1.5 (essential facilities - hospitals, police & fire stations)
 I = 1.25 (large occupancy)
 I = 1 (all other facilities)

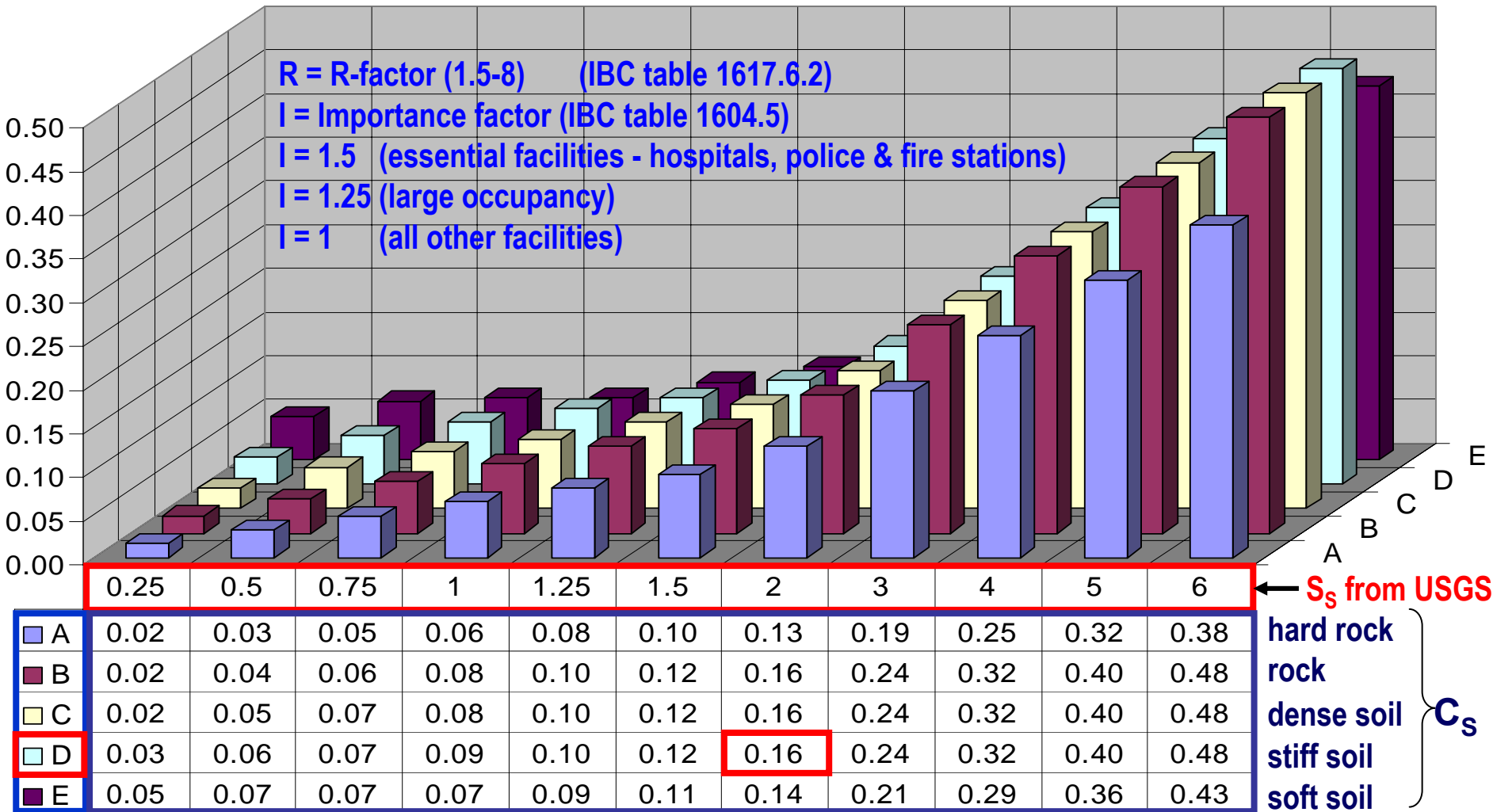

Cs for site class A-E for 0.2 sec mapped spectral accelerations S_s (top line)

Site class A-E defined by geologist (default site class D)

Example: Two-story LA residence, 2200 ft², DL = 15 psf, I = 1, site class D

Enter zip code at USGS web site: <http://eqint.cr.usgs.gov/eq/html/zipcode.html>

Web site output: 0.2 sec SA 116.310 135.513 185.24

$S_s = 1.85$

Seismic coefficient C_s (see graph, at $S_s = 2.0 > 1.85$)

$C_s = 0.16$

Cs factors for light framing with wood panels (R=6, I=1)

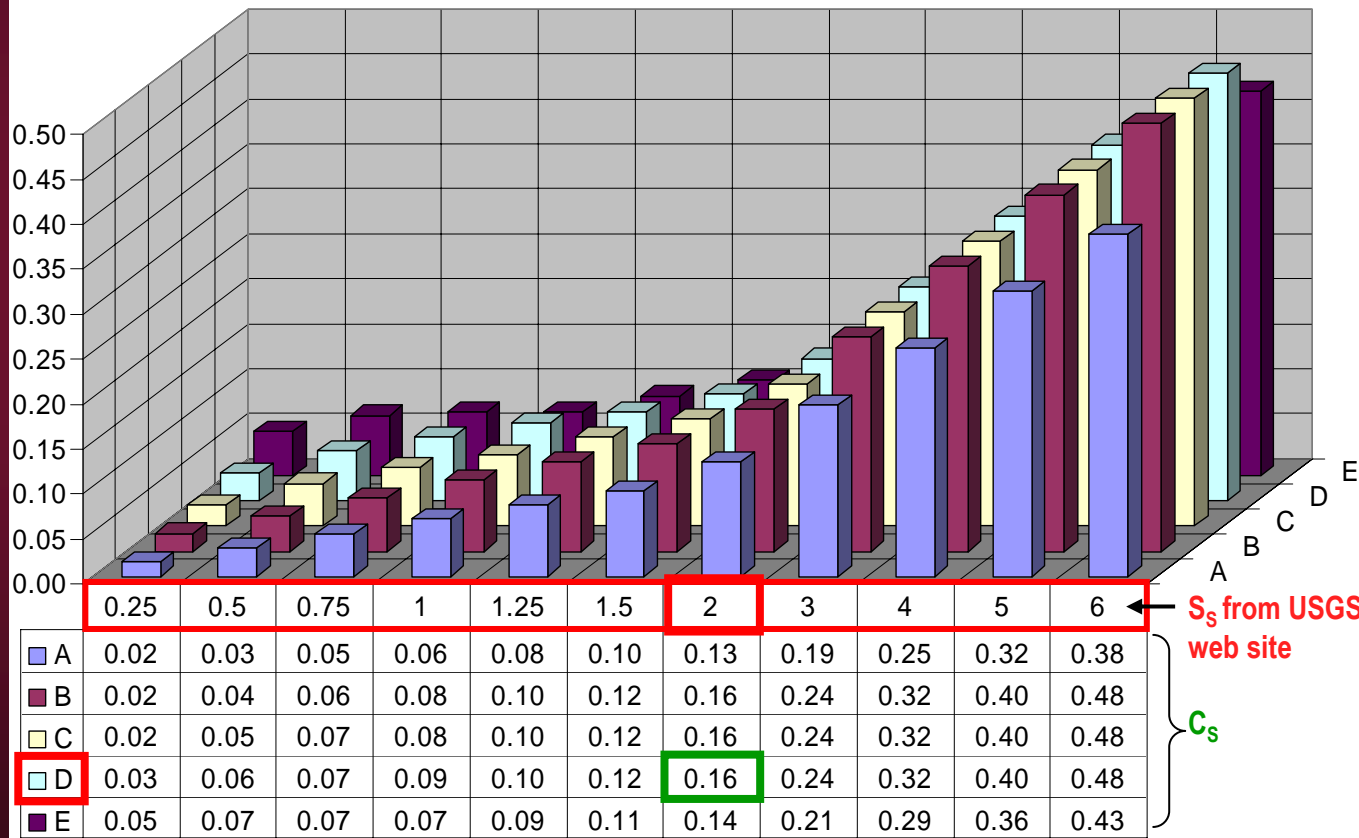

Cs for site class A-E for 0.2 sec mapped spectral accelerations Ss (top line)

Building dead weight

$W = 15 \text{ psf} \times 2200 \text{ ft}^2$

$W = 33,000 \#$

Base shear

$V = C_s W$

$V = 0.16 \times 33,000 \#$

$V = 5,280 \#$

Base Shear (from last page)

Shear walls required - use 3/8 panels, 8d nails at 6"

$L' = V / q = 5,280 / 230 = 23'$ (total length each way)

Wall A: $L = 23' / 2 = 11.5'$ (~ symmetry)

Wall B: $L = 23' \times 20' / (10+20) = 15.3'$

Wall C: $L = 23' \times 10' / (10+20) = 7.7'$

$V = 5,280 \#$

$q = 230 \text{ plf}$

use 12' walls

use 16' wall

use 8' wall

Walls B & C are inversely proportional to distance from centroid of mass

IBC table 2306.4.1 excerpts

Allowable shear for wood panels with Douglas-Fir-Large or Southern Pine

| Panel grade | Panel thickness | Nail penetration | Nail size | Nail spacing at panel edge (inches) | | | |
|------------------------|-----------------|------------------|-----------|-------------------------------------|-----|-----|-----|
| | | | | 6 | 4 | 3 | 2 * |
| Structural I sheathing | 5/16 in | 1 1/4 in | 6d | 200 | 300 | 390 | 510 |
| | 3/8 in | 1 3/8 in | 8d | 230 | 360 | 460 | 610 |
| | 7/16 in | 1 3/8 in | 8d | 255 | 395 | 505 | 670 |
| | 15/32 in | 1 3/8 in | 8d | 280 | 430 | 550 | 730 |
| | | 1 1/2 in | 10d | 340 | 510 | 665 | 870 |

* Requires 3 x framing and staggered nailing

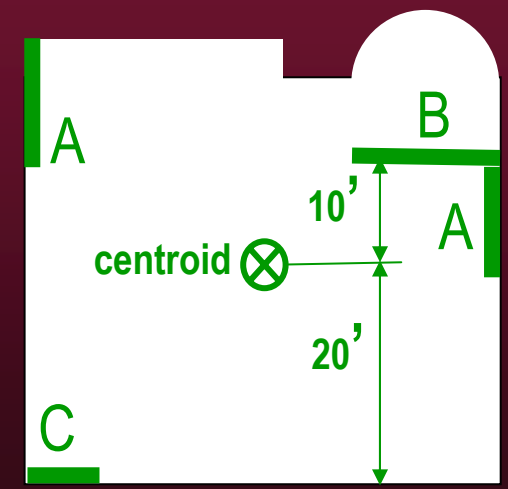

Low-rise (general)

$$C_s = I S_{DS} / R$$

| | |
|--------------------------------------|-----|
| IBC table 1617.6.2 R-factor excerpts | R |
| Light framed walls with wood panels | 6 |
| Ordinary plain concrete shear wall | 1.5 |

S_{DS} graph 0.2 sec. design spectral accelerations

R = R-factor (1.5-8) (IBC table 1617.6.2)
 I = Importance factor (IBC table 1604.5)
 I = 1.5 (essential facilities - hospitals, police & fire stations)
 I = 1.25 (large occupancy)
 I = 1 (all other facilities)

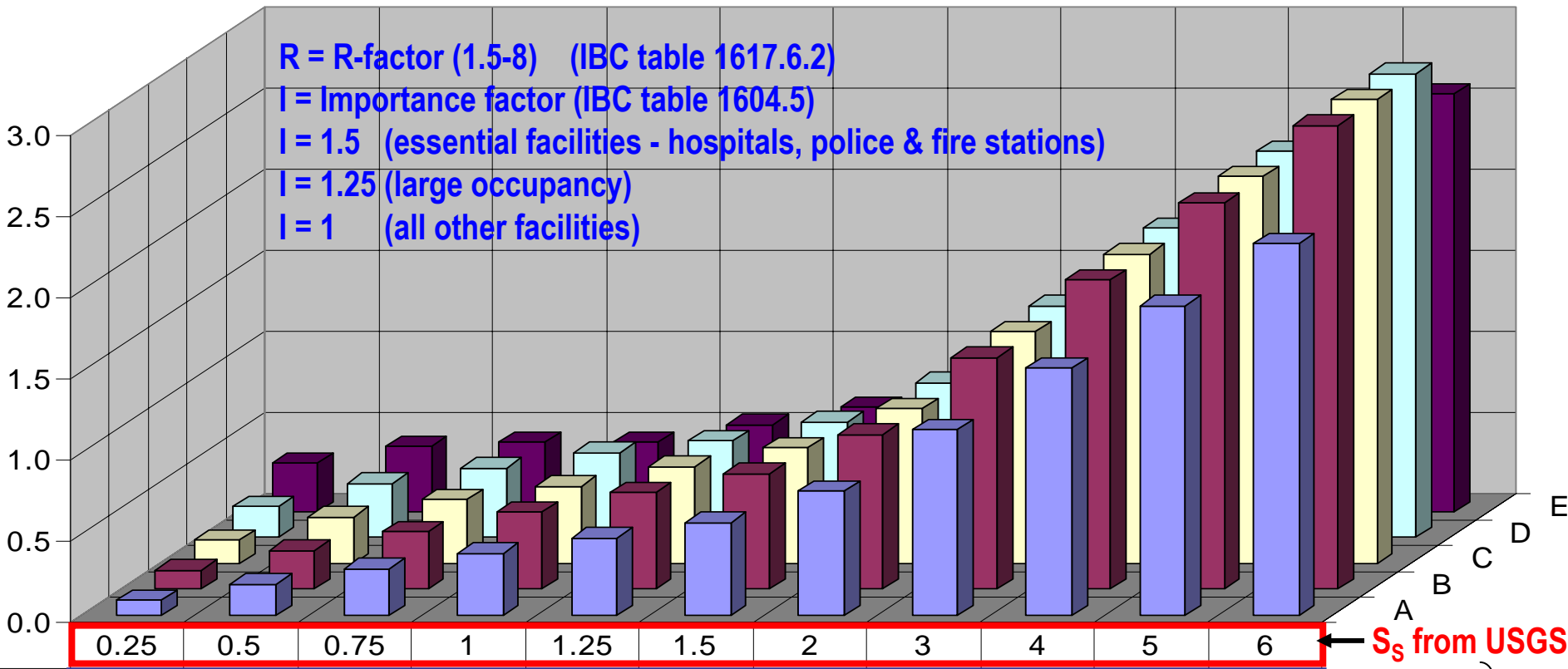

| | 0.25 | 0.5 | 0.75 | 1 | 1.25 | 1.5 | 2 | 3 | 4 | 5 | 6 | |
|---|------|------|------|------|------|------|------|------|------|------|------|---|
| A | 0.10 | 0.19 | 0.29 | 0.38 | 0.48 | 0.57 | 0.76 | 1.14 | 1.52 | 1.90 | 2.28 | } S_{DS} hard rock rock dense soil stiff soil soft soil |
| B | 0.12 | 0.24 | 0.36 | 0.48 | 0.60 | 0.71 | 0.95 | 1.43 | 1.90 | 2.38 | 2.86 | |
| C | 0.14 | 0.29 | 0.39 | 0.48 | 0.60 | 0.71 | 0.95 | 1.43 | 1.90 | 2.38 | 2.86 | |
| D | 0.19 | 0.33 | 0.43 | 0.52 | 0.60 | 0.71 | 0.95 | 1.43 | 1.90 | 2.38 | 2.86 | |
| E | 0.30 | 0.40 | 0.43 | 0.43 | 0.54 | 0.64 | 0.86 | 1.29 | 1.71 | 2.14 | 2.57 | |

High-rise

$(T > T_s)$

$C_s = I S_{D1} / (TR)$

$(T_s = S_{DS} / S_{D1})$

IBC table 1617.6.2 R-factor excerpts

Ordinary composite braced frames

Special steel moment frames

| |
|---|
| R |
| 3 |
| 8 |

S_{D1} graph 1 sec. design spectral accelerations

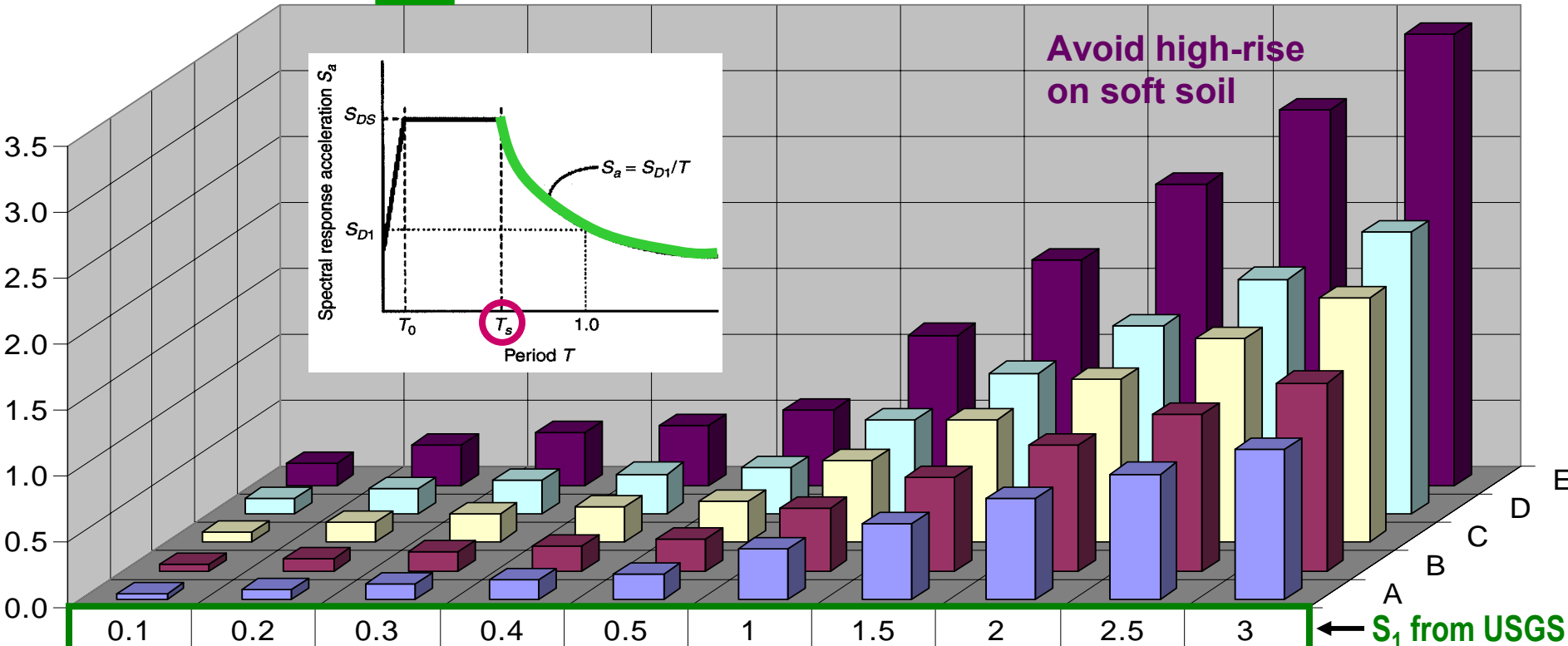

| | 0.1 | 0.2 | 0.3 | 0.4 | 0.5 | 1 | 1.5 | 2 | 2.5 | 3 | |
|---|------|------|------|------|------|------|------|------|------|------|---|
| A | 0.04 | 0.08 | 0.11 | 0.15 | 0.19 | 0.38 | 0.57 | 0.76 | 0.95 | 1.14 | ← S_1 from USGS hard rock rock dense soil stiff soil soft soil |
| B | 0.05 | 0.10 | 0.14 | 0.19 | 0.24 | 0.48 | 0.71 | 0.95 | 1.19 | 1.43 | |
| C | 0.08 | 0.15 | 0.21 | 0.27 | 0.31 | 0.62 | 0.93 | 1.24 | 1.55 | 1.86 | |
| D | 0.11 | 0.19 | 0.26 | 0.30 | 0.36 | 0.71 | 1.07 | 1.43 | 1.79 | 2.14 | |
| E | 0.17 | 0.30 | 0.40 | 0.46 | 0.57 | 1.14 | 1.71 | 2.28 | 2.86 | 3.43 | |

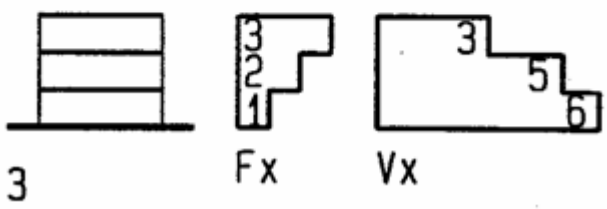
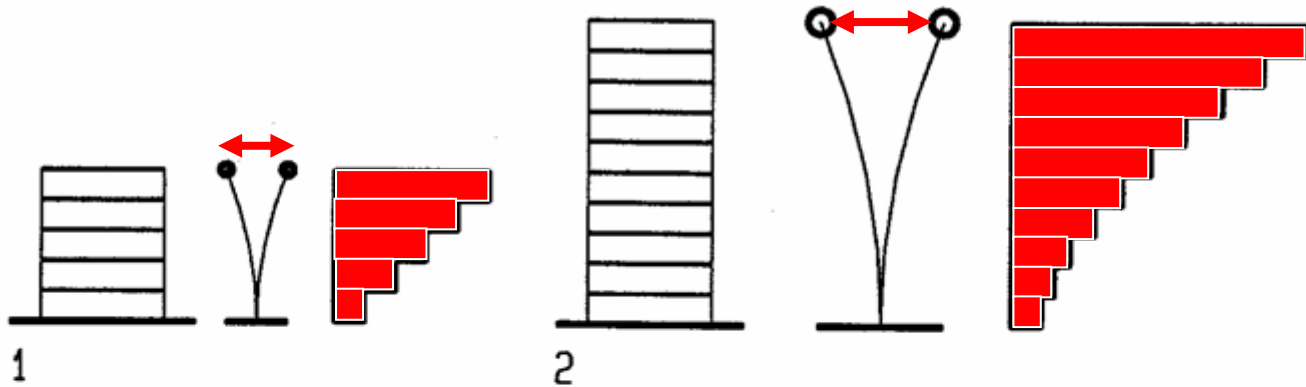

Example:

| | |
|------------|--------------------|
| $F_3 = 3k$ | $V_3 = 3k$ |
| $F_2 = 2k$ | $V_2 = 3+2 = 5k$ |
| $F_1 = 1k$ | $V_1 = 3+2+1 = 6k$ |

Force per level x

$$F_x = C_{vx} V$$

$$C_{vx} = w_x h_x^k / \sum_{i=1}^n w_i h_i^k$$

Shear per level x

$$V_x = \sum_{i=x}^n F_i$$

where

V = base shear

h = height of level

w = DL per level

k = 1 for T < 0.5 sec

k = 2 for T ≥ 2.5 sec

interpolate @ 0.5-2.5

Vertical force & shear distribution

Seismic forces increase with height due to increased acceleration

- 1 Linear low-rise force increase
- 2 Non-linear high-rise force increase
- 3 Three-story example

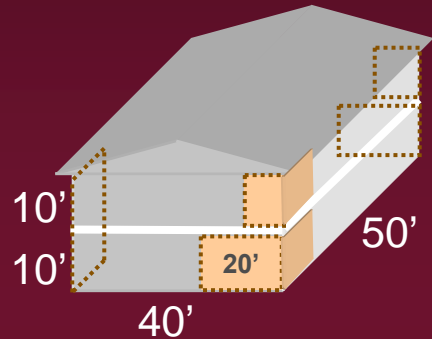
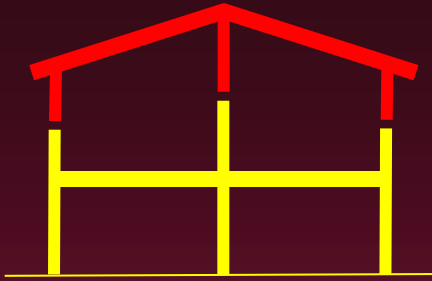

Example: Two-story wood residence

DL = 24 psf (floor+walls), 13.5 psf (roof+walls) $C_s = 0.16$

Dead load (DL)

Roof DL = W = 13.5 psf x 40' x 50' / 1000 # $W = 27 \text{ k}$

Floor DL = W = 24 psf x 40' x 50' / 1000 # $W = 48 \text{ k}$

Base shear

$V = W C_s = (27+48) 0.16$ $V = 12 \text{ k}$

Vertical distribution $(0.53 = 540 / 1,020)$

$F_x = V w_x h_x / \sum (w_i h_i)$ $(0.47 = 480 / 1,020)$

Level: $w_x h_x = w_x h_x$ V F_x V_x

Roof: $27 \text{ k} \times 20' = 540 \text{ k}'$ $0.53 \times 12 \text{ k} = 6.4 \text{ k}$ 6.4 k

Floor: $48 \text{ k} \times 10' = 480 \text{ k}'$ $0.47 \times 12 \text{ k} = 5.6 \text{ k}$ 12.0 k

$\sum w_i h_i = 1,020 \text{ k}'$ $V = 12.0 \text{ k}$

Shear wall: use 5/16" plywood, 6d @ 4", q = 300 plf

L = 12,000 # / 300 plf $L = 40'$

Use each way $2 - 20' \text{ walls}$

IBC table 2306.4.1 excerpts
Allowable shear for wood panels with
Douglas-Fir-Large or Southern Pine (Structural I sheathing)

| Panel thickness | Nail penetration | Nail size | Nail spacing at panel edge (in) | | | |
|-----------------|------------------|-----------|---------------------------------|-----|-----|-----|
| | | | 6 | 4 | 3 | 2* |
| | | | Allowable shear (lbs / foot) | | | |
| 5/16 in | 1 1/4 in | 6d | 200 | 300 | 390 | 510 |
| 3/8 in | 1 3/8 in | 8d | 230 | 360 | 460 | 610 |
| 7/16 in | 1 3/8 in | 8d | 255 | 395 | 505 | 670 |
| 15/32 in | 1 3/8 in | 8d | 280 | 430 | 550 | 730 |
| | 1 1/2 in | 10d | 340 | 510 | 665 | 870 |

* Requires 3 x framing and staggered nailing

Horizontal Diaphragms

transfer lateral load to shear walls and other elements two ways

1 Flexible diaphragm (wood)

transfers in proportion to tributary area.

Wall reactions are:

$R = w$ (tributary area supported by wall)

$w =$ uniform load

2 Rigid diaphragm (concrete & steel)

transfers in proportion to wall stiffness.

Reactions for walls of equal material:

$$R1 = WL1^3 / \Sigma L^3 \quad (\Sigma L^3 = L1^3 + L2^3 + L3^3)$$

$$R2 = WL2^3 / \Sigma L^3$$

$$R3 = WL3^3 / \Sigma L^3$$

where

$L =$ Lengths of walls

$W =$ Total load supported by all walls

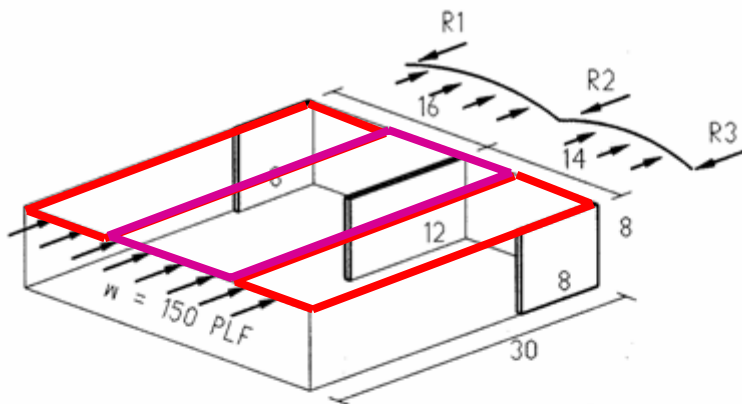

1

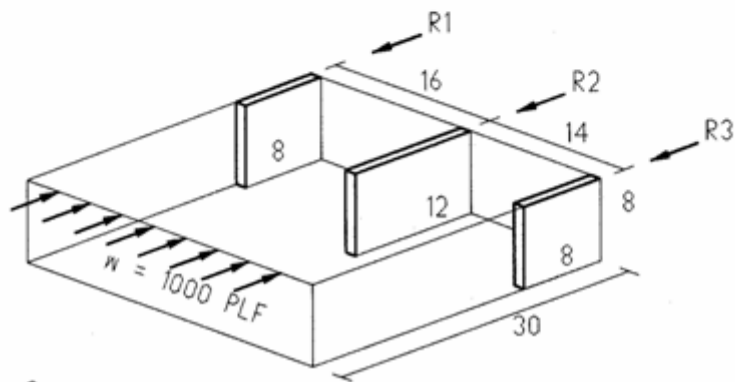

2



Hillside design

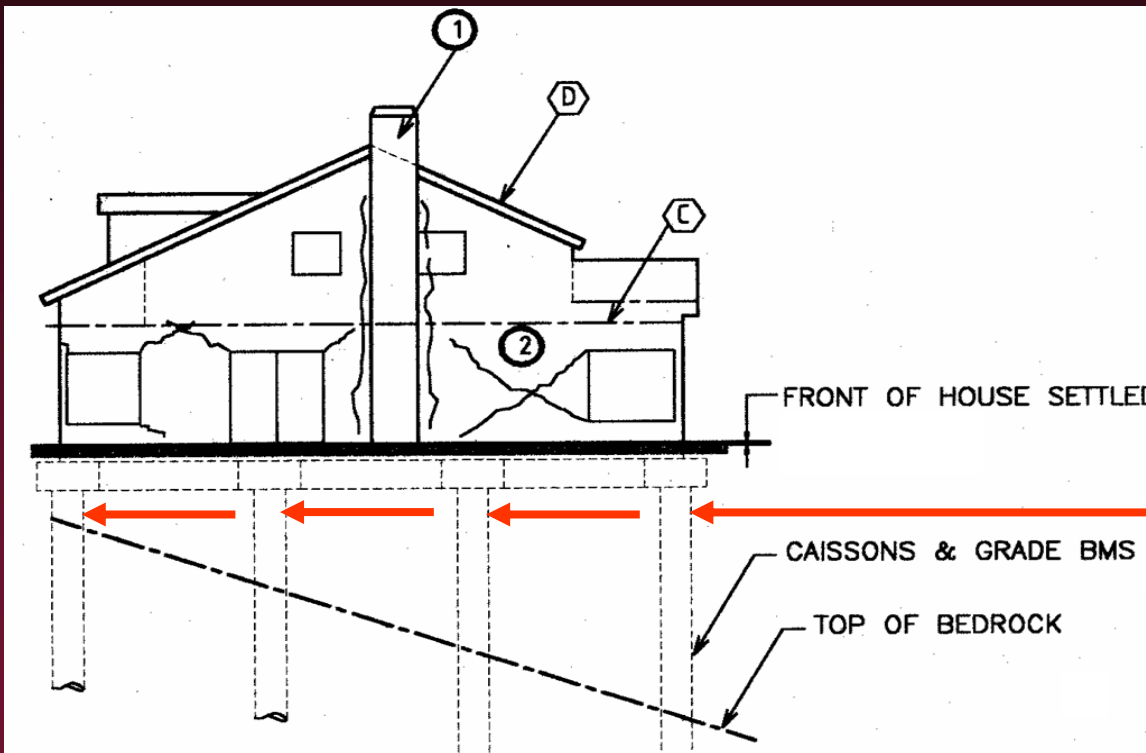

To avoid expensive earthquake repair

..... adapt buildings to site – instead of adapting site to buildings

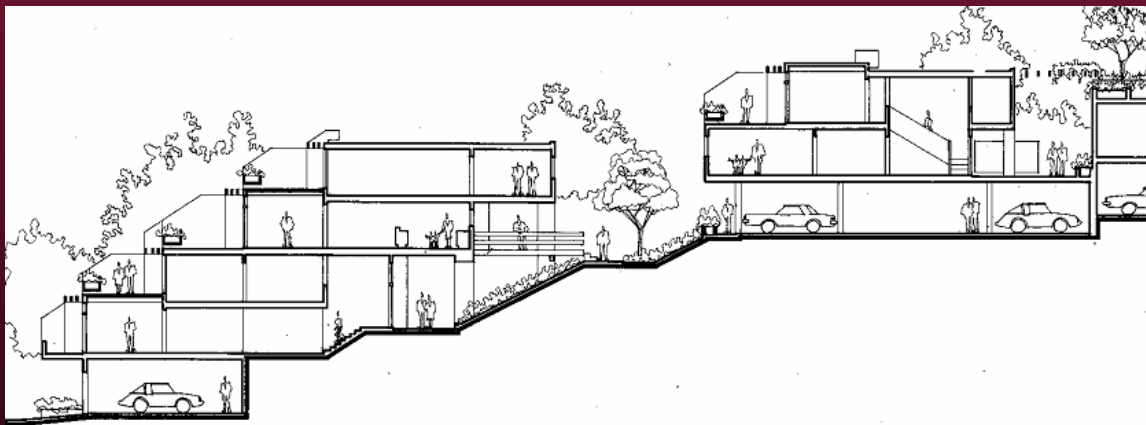

sustainable design
reduces grading
and retaining walls

Stability issues

1 Narrow multistory shear walls are vulnerable to overturning

2 Mitigations:

A Join windows for wider shear walls

B Attach shear walls to edge beam

3 Narrow shear wall failure

4 Tuck-under parking collapse

5 Use moment frames to resist collapse

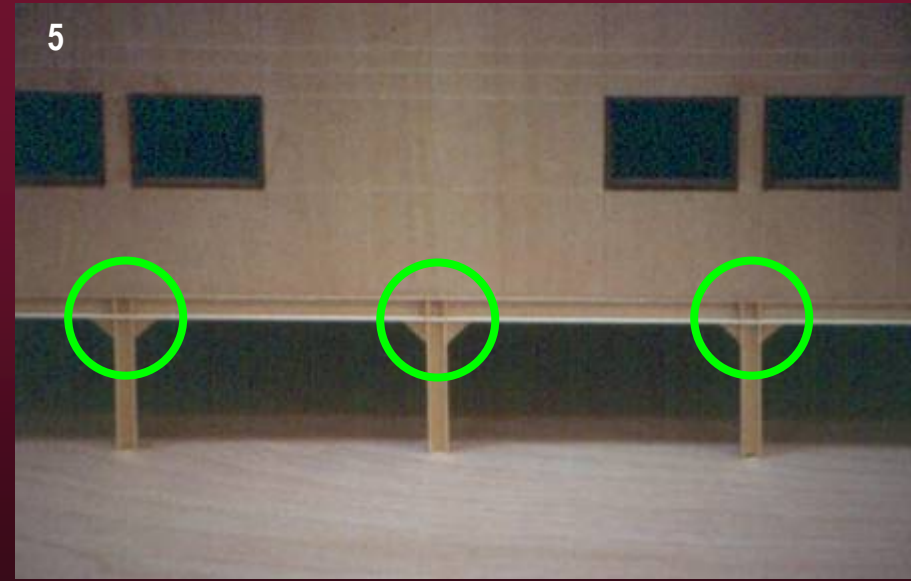
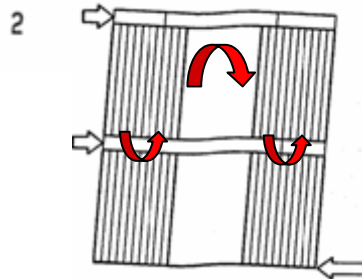
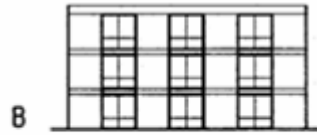
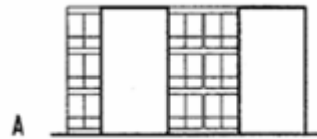
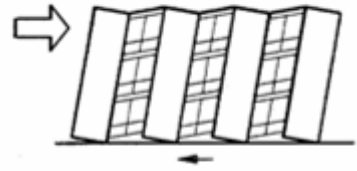

Eccentricity issues (avoid it)

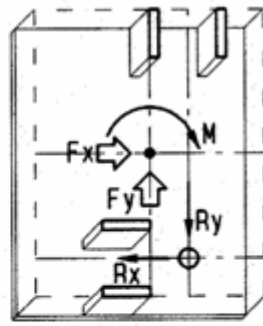
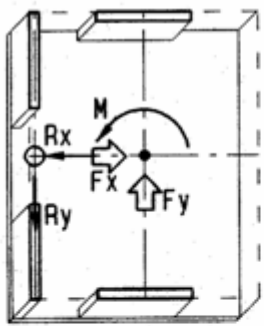

1 ☹️ 2 ☹️

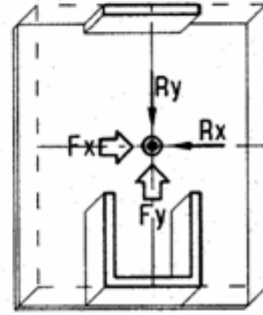
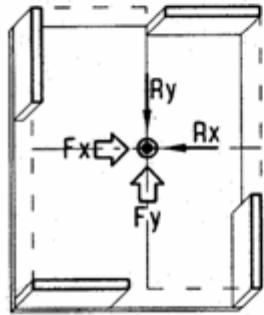

3 😊 4 😊

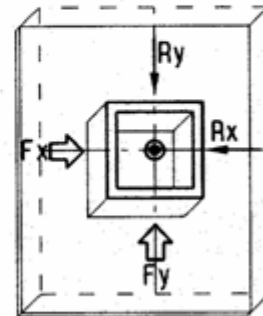
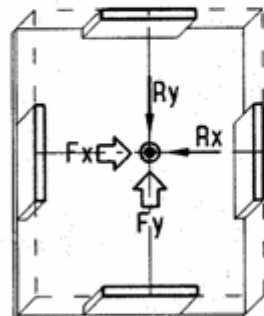

5 😊 6 😊

1 X-direction concentric

Y-direction eccentric

2 X-direction eccentric

Y-direction eccentric

3 X-direction concentric

Y-direction concentric

4 X-direction concentric

Y-direction concentric

5 X-direction concentric

Y-direction concentric

6 X-direction concentric

Y-direction concentric

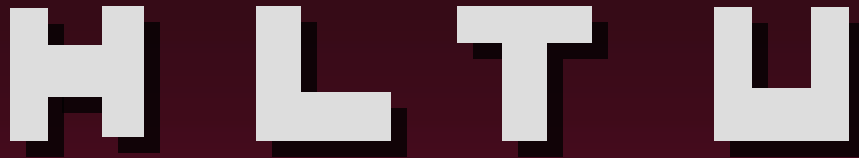

Hazard Configurations

Differential periods split wings



Wings split during Northridge Earthquake

Mitigations:

- Joints at low-rise intersections
- Reinforce high-rise intersections
(to prevent pounding of adjacent wings)

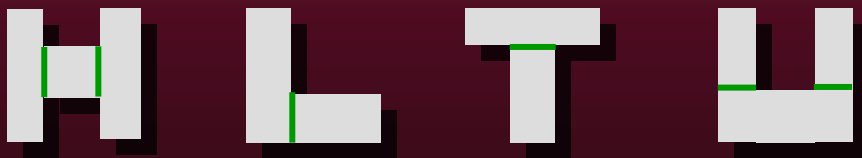

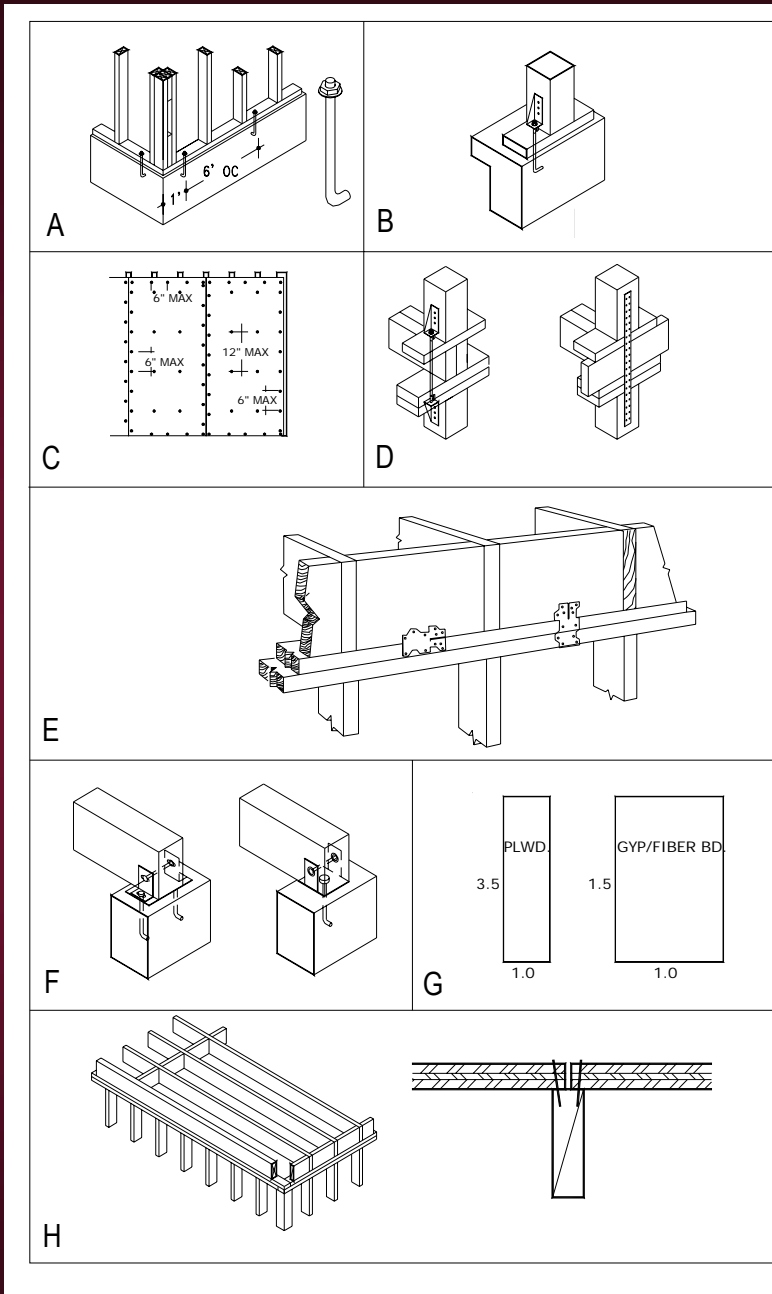

Critical woodframe items

- A Shear wall anchor bolts
Resist wall slippage
- B Hold-down
Resist shear wall overturning
- C Shear wall nailing
Attaches panels to framing
- D Wall-to-wall hold-down
Resist shear wall overturning
- E Framing anchor clips
Transfer shear from floor to floor
- F Beam connection
Resist beam slippage
- G Shear wall width/height ratio
Minimum 1 : 3.5 for stability
- H Joist blocking
Transfers shear at panel edges

Moment frames

Provide ductility

Require rigid
beam-column joints
to transfer moments

Steel:

Reduced beam flanges
reduce joint stress

I = inflection points of zero bending stress

Concrete:

Extend rebars through beam & column

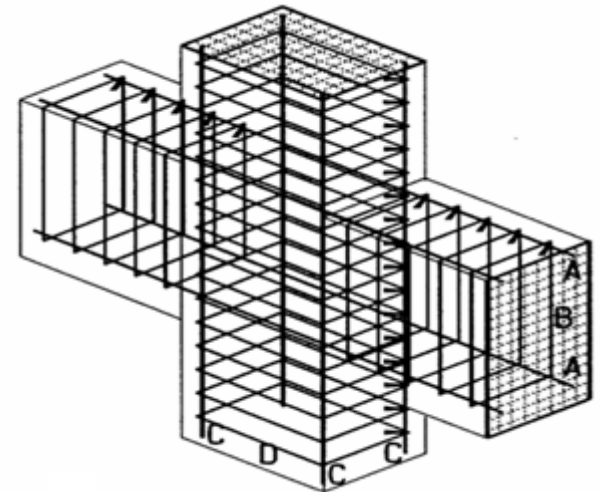
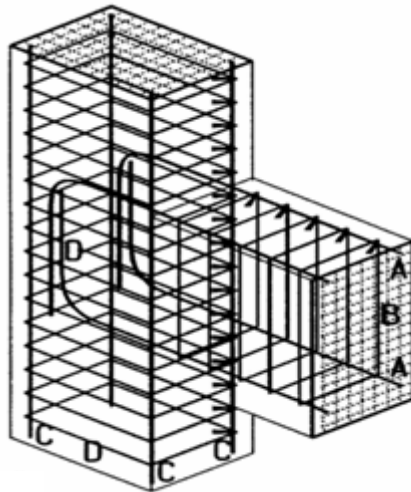
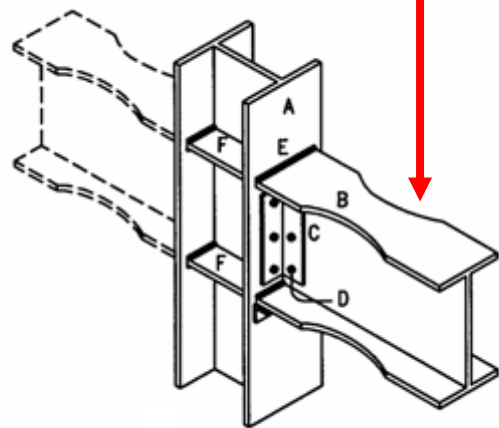
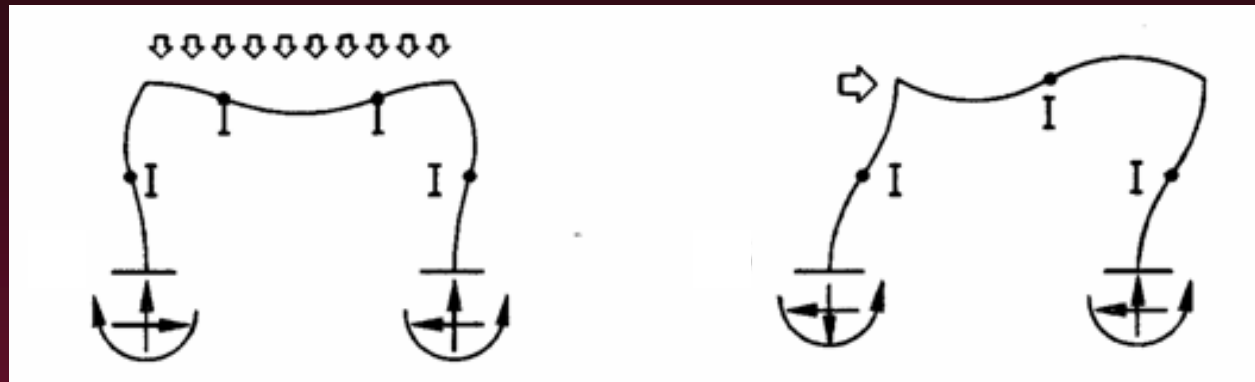

↔ *Link Beam*



Eccentric bracing

- Short *Link Beam* for stiffness
- Long *Link Beam* for ductility

Visco elastic bracing

- Stiff at normal load
- Ductile at large earthquakes





Base Isolators

- Dampen seismic load and reduce drift
- Good for low-rise
- Not good for high-rise

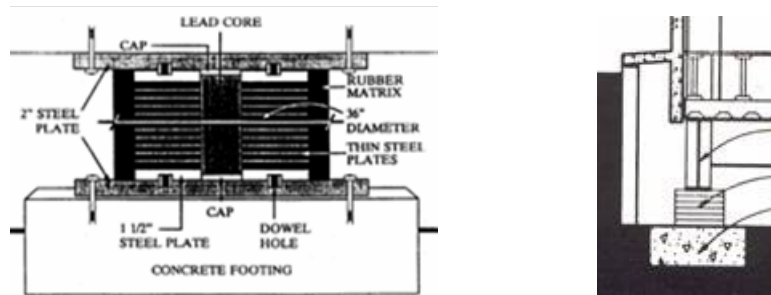

Base isolators consist of

- Rubber sheets and steel plates
- Joined by a bolt and lead cylinder
- Isolate building from ground



UCLA Kerckhoff Hall base isolators
 Courtesy WWCOT Architects

Fatalities of major earthquakes 1970 - 1999 (USGS data)

Seismic design saves lives

| Date | Time GMT | Place | Latitude | Longitude | Fatalities | M |
|-------------------------|--------------|-------------------------|--------------|----------------|------------|------------|
| May 31, 1970 | 20:23 | Peru | -9.25 | -78.84 | 66,000 | 7.9 |
| February 9, 1971 | 14:00 | San Fernando, CA | 34.40 | -118.39 | 65 | 6.7 |
| February 4, 1975 | 11:36 | Haicheng, China | 40.72 | 122.73 | 10,000 | 7.0 |
| February 4, 1976 | 09:01 | Guatemala | 15.30 | -89.14 | 23,000 | 7.5 |
| July 27, 1976 | 19:42 | Tangshan, China | 39.61 | 117.89 | 255,000* | 7.5 |
| September 19, 1985 | 13:17 | Michoacan, Mexico | 18.44 | -102.36 | 9,500 | 8.0 |
| December 7, 1988 | 07:41 | Spitak, Armenia | 40.93 | 44.11 | 25,000 | 6.8 |
| October 18, 1989 | 00:04 | Loma Prieta, CA | 37.14 | -121.76 | 63 | 6.9 |
| September 2, 1992 | 00:16 | Nicaragua | 11.77 | -87.35 | 116 | 7.7 |
| September 29, 1993 | 22:25 | Latur-Killari, India | 18.08 | 76.52 | 9,748 | 6.2 |
| January 17, 1994 | 12:30 | Northridge, CA | 34.18 | -118.56 | 60 | 6.7 |
| January 16, 1995 | 20:46 | Kobe, Japan | 34.57 | 135.03 | 5,502 | 6.9 |
| July 17, 1998 | 08:49 | New Guinea | -2.94 | 142.58 | 2,183 | 7.0 |
| January 25, 1999 | 18:19 | Colombia | 4.45 | -75.65 | 1,185 | 6.2 |
| August 17, 1999 | 00:01 | Izmit, Turkey | 40.77 | 30.00 | 17,118 | 7.6 |
| September 20, 1999 | 17:47 | Chi-Chi, Taiwan | 23.82 | 120.86 | 2,400 | 7.7 |

Light-weight structures minimize seismic forces

$$V = C_S W$$



Saddle shape



Wave shape



Arch shape



Point shape